











292 Kennedys Bush Road
Interior Design Preliminary Concept

LEGEND

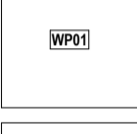
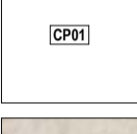
	Carpet Andes Peak Colour - Patila
	Engineered Timber Flooring Forle Lift Colour - Stamford Feature Trim Colour - Brushed Copper
	Floor Tile Dhara Neutral Stone Effect 60x120 Grout Colour - TBC Min Thickness Tile Trim Colour - Brushed Copper
	Wall Tile Dhara Neutral Stone Effect 60x120 Grout Colour - TBC Min Thickness Tile Trim Colour - Brushed Copper
	Feature Wall Tile Dhara White Decor Fluted 30x60 Grout Colour - TBC Min Thickness Tile Trim Colour - Brushed Copper
	Laundry Wall Tile Client Supplied
	Brick Continuation of Exterior Cladding
	Wall Paint Resene Half Merino N94-006-090 (To all walls, unless noted on Internal Elevations)
	Ceiling Paint Resene Half Merino N94-006-090
	Joinery - Bench & Panel 12mm Neolith Colour - Taj Mahal
	Joinery - Panels (Timber) Melleca - Organic Colour - Aged Ash
	Joinery - Panels (White) Melleca Satin Colour - Snowdrift
	Feature Glass Smoked & Reeded glass to joinery

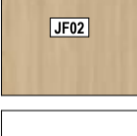
DR	Drawer	FF	Floor Finish
CUPD	Hinged Cupboard	WF	Wall Finish
PTO	Push To Open	WP	Wall Paint
FXD	Fixed	CP	Ceiling Paint
ADJ	Adjustable	JF	Joinery Finish
TS	Toe-space		

JOINERY NOTES

Joinery Notes

Joinery shall confirm all fittings, fixtures, appliances and check all dimensions onsite prior to fabrication.

Joinery Components

Melamine sizes: Allow for 18mm thick carcass partitions, shelves, perimeter frame. Doors, drawer fronts & doors.

Carcass Backing: 9mm selected melamine.

Carcass Colour: Generally 'Melleca Storm' for timber fronts or 'Melleca Snowdrift' for white fronts unless otherwise specified. Refer joinery for details. Exposed front edges to have matching edge tape to fronts.

Door & Drawer Fronts: All doors and drawers with no handle to be on magnetic push catches sized for weight of door / drawer.

Edge Tape: Ensure all 1mm PVC edge tape is square edge and not round edge.

Door Hinges: All doors shall be hinged on blum soft closing 110° clip blumotion hinges unless otherwise specified.

Drawers: 550 deep 'Orion Grey' blum Merivox drawers. Except where joinery is white then 'Silk White Matt' Merivox drawers.

Stabilisers: Allow for stabilisers to all drawers exceeding 1m in width.

Matting: Allow for blum matting to all drawer bases (other than vanity unit drawers). Do not stick matting to drawer base (as per suppliers instructions).

Drawer Runners: Generally use Blum full extension runners in grey finish.

Cutlery Components: Where indicated, allow for various cutlery drawer inserts to suit drawer width.

Appliances: Joiner shall confirm all appliance dimensions & manufacturer's requirements prior to carcass fabrication. Joiner shall liaise with electrician for installation of appliances. Allow for isolation switches for oven and hob where shown on elevations and electrical plan.

Plumbing notes

AFFL - above finished floor level

CL - centre line

Nogs: Solid nogs to be provided for fittings and fixtures including toilet roll holders.

Plumber to confirm all dimensions and manufacturer's requirements prior to commencing work.

Slide Showers: Rose of all slide showers set at 2000mm AFFL, water inlet elbow set at 1100mm AFFL.

Shower Mixer: 1100mm AFFL.

Toilet Roll Holder: Generally aligned with front edge of toilet seat 550 AFFL to CL.

Blum Hardware Spec:

- All kitchen, laundry, wardrobe drawers to be Merivox. Where timber joinery, to be Orion Grey finish & where white joinery, to be Silk White Matt finish. 550mm runners where double, drawer side heights to suite. Use 70kg runners and front base stabilisers where appropriate.
- Blum Clip Top Blumotion Onxy Black integrated softclose hinges to all cupboard doors. Opening angle stops where required.
- Blum non slip matting to all drawers.
- Blum Ambia-line Accessories For Kitchen : 2x Ambia-line Starter Packs In Carbon Black & 1x Cutlery Insert

DOOR HARDWARE

Passage Lever:

ABI Davis Door Handle
Brushed Copper
Sku: 12890

Privacy Lock:

ABI Dion Privacy Smb lock
Brushed Copper
Sku: 12986

Privacy Cavity Slider:

ABI Leroy Sliding Door Privacy Set
Brushed Copper
Sku: 15275

Cavity Slider:

ABI Leroy Sliding Door Dummy Pull
Brushed Copper
Sku: 17008

End Pull - All Cavity Sliders

ABI Cavity Slider Edge Pull
Brushed Copper
Sku: 16440

Door Stop

ABI Kolton Door Stop
Brushed Copper
Sku: 12774

SCHEDULE - KITCHEN

Fridge	Fisher + Paykel 60cm Series 9 Integrated Dual Zone Refrigerator RS6019SZR1
Freezer	Fisher + Paykel 60cm Series 9 Integrated Dual Zone Freezer CR5019FZL1
Oven	Fisher + Paykel 60cm Series 9 Minimal Handleless Pyrolytic Oven OB605MPTNB1
Hob	Fisher + Paykel 90cm Series 9 5 zone Induction Cooktop CI9050TTB1
Dishdrawer	Fisher + Paykel Integrated Double Dishdrawer DD600D9
Rangehood	Fisher + Paykel Undermount Powerpeak Rangehood, 90cm W/ External Motor HPB902B-1
Wine Fridge	Vintec Wine Fridge with 35 Bottle Capacity, Black VWS035SBB-X
Tap	ABI Elysian Commercial Pull-Out Kitchen Mixer Brushed Copper Sku: 11696
Sink	ABI Seba Single Kitchen Sink 550mm (overflow) Brushed Copper Sku: 12257
Bin	Fit-N-Z Tanova Designer Series 2 Kitchen Bix 400mm 2x24L - Grey & Charcoal (Soft Close) TFB40224SIMG

SCHEDULE - SCULLERY

Dishdrawer	Fisher + Paykel Integrated Tall Single Dishdrawer DD605T9
Tap	ABI Elysian Commercial Pull-Out Kitchen Mixer Brushed Copper Sku: 11696
Sink	ABI Seba Single Kitchen Sink 550mm (overflow) Brushed Copper Sku: 12257

SCHEDULE - LAUNDRY

WM	Fisher + Paykel Front Loader Washing Machine, 11kg, ActiveIntelligence, Steam Care, Graphite WH1160HG1
DR	Fisher + Paykel Heatpump Dryer, 9kg, Steam Care DR9060HG1
Tap	ABI Elysian Commercial Pull-Out Kitchen Mixer Brushed Copper Sku: 11696
Sink	ABI Seba Single Kitchen Sink 550mm (overflow) Brushed Copper Sku: 12257
Extraction	Round Frameless Grille Ventech 270 Dia VRG270

SCHEDULE - HALLWAY

Hook	ABI Milani Robe Hook (x5) Brushed Copper Sku: 11682
-------------	---

SCHEDULE - BATHROOM

Basin	ABI Labello Thin Edge Basin Sink Matte White Sku: 11861
Basin Waste	ABI Avi Pop-Up Waste White Sku: 11768
Basin Waste Lid	ABI Lid Avi Pop-Up Matte White Sku: 11742
Tapware	ABI Milani Progressive Mixer & Spout Set Matte White Sku: 14280
Shower Rail	ABI Elysian Shower Rail Brushed Copper Sku: 12934
Shower Head	ABI 3-Function Round Hand Shower Brushed Copper Sku: 11914
Shower Hose	ABI Milani Progressive Mixer & Spout Set (x2) Brushed Copper Sku: 10834
Shower BP	ABI Round Shower BP Brushed Copper Sku: 11392
Shower Mixer	ABI Milani Progressive Single Mixer Brushed Copper Sku: 14227
Shower Waste	Custom Channel Drain Tile Insert Colour To Match Grout
Shower Door Hinge	ABI Kenzie Glass to Glass Shower Hinge Brushed Copper Sku: 11849
Shower Door Handle	ABI Livio Shower Door Handle Brushed Copper Sku: 12144
Bath	ABI Odella Solid Surface Free Standing Bath Matte White 1800mm Sku: 10418
Bath Waste	ABI Bath Bend Pop Down with Connector Gloss White Sku: 16708
Bath Spout & Mixer	ABI Milani Progressive Mixer & Spout Set Brushed Copper Sku: 14280
Towel Rail	ABI Milani Heated Towel Rail (x2) Brushed Copper Sku: 11716
Mirror	ABI Airo Mirror 1000 x 625mm Brushed Copper Sku: 17254
Demister Pads	Universal Mirror Demister Pad 500x850mm UMP70
Extraction	Round Frameless Grille Ventech 270 Dia VRG270

SCHEDULE - POWDER ROOM

Toilet	Plumbline Zen II Rimless Floor Mount Toilet With Slim Seat Matt White ZEN54FSLMW
Toilet Cistern	ABI In-Wall Toilet Cistern Sku: 10765
Toilet Button	Zaaha Toilet Button Round Brushed Copper Sku: 12432
Toilet Roll Holder	ABI Milani Toilet Roll Holder Brushed Copper Sku: 11683
Tapware	ABI Milani Swivel Hob Mixer Set Brushed Copper Sku: 15897
Basin	Marmo 550 Rectangle Left Wall Basin Travertine MASWL-TR
Extraction	Round Frameless Grille Ventech 270 Dia VRG270

SCHEDULE - ENSUITE (MASTER)

Toilet Pan	Plumbline Zen II Rimless Floor Mount Toilet With Slim Seat Matt White ZEN54FSLMW
Toilet Cistern	ABI In-Wall Toilet Cistern Sku: 10765
Toilet Button	Zaaha Toilet Button Round Brushed Copper Sku: 12432
Basin	ABI Labello Thin Edge Basin Sink (x2) Matte White Sku: 11861
Basin Waste	ABI Avi Pop-Up Waste (x2) White Sku: 11768
Basin Waste Lid	ABI Lid Avi Pop-Up (x2) Matte White Sku: 11742
Tapware	ABI Milani Progressive Mixer & Spout Set (x2) Brushed Copper Sku: 14280
Shower Rainhead	ABI Shower Head Round 250mm Brushed Copper Sku: 10830
Shower Dropper	ABI Shower Dropper Round 300mm Brushed Copper Sku: 16444
Shower Rail	ABI Elysian Shower Rail Brushed Copper Sku: 12934
Shower Head	ABI 3-Function Round Hand Shower Brushed Copper Sku: 11914
Shower Hose	ABI Shower Hose Brushed Copper Sku: 10834
Shower BP	ABI Round Shower BP Brushed Copper Sku: 11392
Shower Mixer Rain Head	ABI Milani Progressive Single Mixer Brushed Copper Sku: 14227
Shower Mixer Hand Held	ABI Milani Progressive Single Mixer Brushed Copper Sku: 14227
Shower Waste	Custom Channel Drain Tile Insert Colour To Match Grout
Shower Door Hinge	ABI Kenzie Glass to Glass Shower Hinge Brushed Copper Sku: 11849
Shower Door Handle	ABI Livio Shower Door Handle Brushed Copper Sku: 12144
Towel Rail	ABI Milani Heated Towel Rail (x2) Brushed Copper Sku: 11716
Mirror	Custom Brushed Copper Mirror (x2) (To Match Tapware Colour) 1200x550
Demister Pads	Universal Mirror Demister Pad (x2) 500x850mm UMP70
Toilet Roll Holder	ABI Milani Toilet Roll Holder Brushed Copper Sku: 11683
Extraction	Round Frameless Grille Ventech 270 Dia VRG270

SCHEDULE - ENSUITE (BED 2&3)

Toilet	Plumbline Zen II Rimless Floor Mount Toilet With Slim Seat Matt White ZEN54FSLMW
Toilet Cistern	ABI In-Wall Toilet Cistern Sku: 10765
Toilet Button	Zaaha Toilet Button Round Brushed Copper Sku: 12432
Basin	ABI Labello Thin Edge Basin Sink Matte White Sku: 11861
Basin Waste	ABI Avi Pop-Up Waste White Sku: 11768
Basin Waste Lid	ABI Lid Avi Pop-Up Matte White Sku: 11742
Tapware	ABI Milani Swivel Hob Mixer Set Brushed Copper Sku: 15897
Shower Rainhead	ABI Shower Head Round 250mm Brushed Copper Sku: 10830
Shower Dropper	ABI Shower Dropper 150mm Brushed Copper Sku: 16444
Shower Rail	ABI Elysian Shower Rail Brushed Copper Sku: 12934
Shower Head	ABI 3-Function Round Hand Shower Brushed Copper Sku: 11914
Shower Hose	ABI Shower Hose Brushed Copper Sku: 10834
Shower BP	ABI Round Shower BP Brushed Copper Sku: 11392
Shower Mixer Rain Head	ABI Milani Progressive Single Mixer Brushed Copper Sku: 14227
Shower Mixer Hand Held	ABI Milani Progressive Single Mixer Brushed Copper Sku: 14227
Shower Waste	Custom Channel Drain Tile Insert Colour To Match Grout
Shower Door Hinge	ABI Kenzie Glass to Glass Shower Hinge Brushed Copper Sku: 11849
Shower Door Handle	ABI Livio Shower Door Handle Brushed Copper Sku: 12144
Towel Rail	ABI Modis Adjustable Heated Towel Rail 900mm (x2) Brushed Copper Sku: 17037
Mirror	ABI Airo Mirror 1000 x 625mm Brushed Copper Sku: 17254
Demister Pads	Universal Mirror Demister Pad 500x850mm UMP70
Toilet Roll Holder	ABI Milani Toilet Roll Holder Brushed Copper Sku: 11683
Extraction	Round Frameless Grille Ventech 270 Dia VRG270

ALL MEASUREMENTS TO BE CONFIRMED ON SITE BEFORE COMMENCING ANY CONSTRUCTION. THE COPYRIGHT OF THIS DRAWING REMAINS WITH FIGURE AND GROUND LIMITED.

D	Interior Concept	11/12/2025
---	------------------	------------



FIGURE & GROUND

292 Kennedys Bush Road
Kennedys Bush
Christchurch

Interior Specification.

Drawing Sheet

A6.2

File	25.1029
Date	11/12/2025
Drawn	BM
Revision	D

Figure & Ground
Level 1, 4 Walker Street
Christchurch Central 8011

p. 03 352 4333
e. studio@figureandground.co.nz
w. www.figureandground.co.nz



FIGURE & GROUND

292 Kennedys Bush Road
Kennedys Bush
Christchurch

Floor Finishes Plan.

Drawing Sheet	A6.3
File	25.1029
Date	11/12/2025
Drawn	BM
Revision	D

Figure & Ground
Level 1, 4 Walker Street
Christchurch Central 8011

p. 03 352 4333
e. studio@figureandground.co.nz
w. www.figureandground.co.nz

D	Interior Concept	11/12/2025
---	------------------	------------

Legend

- ⊠ Recessed Downlight - Halcyon R535 Ww3k
- ▽ Eyelid Low Wall Light on Sensor - Halcyon R335 W3
- Recessed Feature Downlight - Halcyon R534 Ww3k
- Soffit Recessed Downlight - Halcyon R688 White
- LED Strip Ribbon in Joinery on Sensor
- Outdoor up-down Wall Light - Finish to match external joinery
- LED Batten - 1500mm Philips CPRE 56W 4K
- Pendant Light - Night Works Studio Code Kilo & Code Charlie in Whiskey Brass Finish
- Wall Light - Shadow Long Wall Light by Lighting Republic
- Light switch (# = number of switches)
- ⊠ Ceiling Mounted Extractor Fan
- ▲ Motion Sensor - House Watch Recessed 360 degree 55-305.



FIGURE & GROUND

292 Kennedys Bush Road
Kennedys Bush
Christchurch

Lighting Plan.

Drawing Sheet	A6.4
File	25.1029
Date	11/12/2025
Drawn	BM
Revision	D

Figure & Ground
Level 1, 4 Walker Street
Christchurch Central 8011

D	Interior Concept	11/12/2025
---	------------------	------------

Legend











-  Powerpoint (# = No. Outlets)
-  Data, HDMI Outlet
-  Fitting Above Bench (1.0m A.F.L.) - 2x 48 Round: Outlet Single - Zetr in White
-  Fitting Side Bench (0.84m A.F.L.) - 2x 48 Round: Outlet Single - Zetr in White
-  Fitting High Level (1.5m A.F.L.)
-  Powerpoint with USB
-  Heated Towel Rail
-  EV Charger Plug
-  Door Bell
-  Switch Board
-  Extractor Fan, Ceiling Mounted



FIGURE & GROUND

292 Kennedys Bush Road
Kennedys Bush
Christchurch

Electrical Plan.

Drawing Sheet	A6.5
File	25.1029
Date	11/12/2025
Drawn	BM
Revision	D

Figure & Ground
Level 1, 4 Walker Street
Christchurch Central 8011

D	Interior Concept	11/12/2025
---	------------------	------------

Legend

- Curtains - Double Track - Sheer to front, Blackout out back, Stack to one side - White - Vanda Flush Fit Track
- Curtains - Double Track - Sheer to front, Blackout out back, Stack both sides - White - Vanda Flush Fit Track
- Blind - Single Flush - Powdercoated to match Joinery - Vanda Recess Flushbox with Cover Plate VA-FB-100 Refer to Arch. Detail 7.1



FIGURE & GROUND

292 Kennedys Bush Road
Kennedys Bush
Christchurch

Window Furnishings Plan.

Drawing Sheet	A6.6
File	25.1029
Date	11/12/2025
Drawn	BM
Revision	D

Figure & Ground
Level 1, 4 Walker Street
Christchurch Central 8011

D	Interior Concept	11/12/2025
---	------------------	------------



03 Scullery Perspective



01 Kitchen Perspective

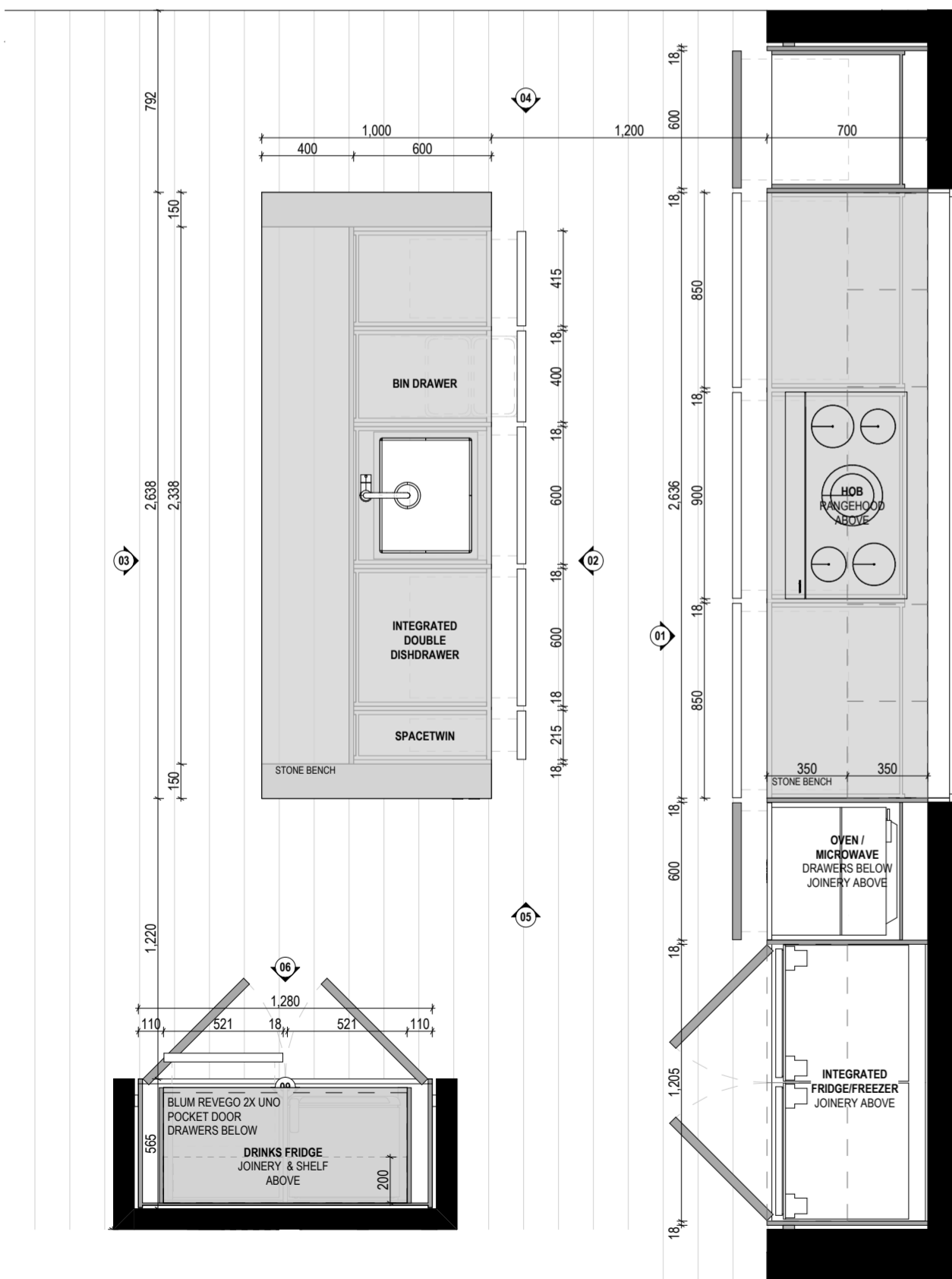

Kitchen Plan

SCALE: 1:25



02 Kitchen Perspective



FIGURE & GROUND

292 Kennedys Bush Road
Christchurch

Kitchen.

Drawing Sheet	A6.7
File	25.1029
Date	11/12/2025
Drawn	BM
Revision	D

Figure & Ground
Level 1, 4 Walker Street
Christchurch Central 8011

p. 03 352 4333
e. studio@figureandground.co.nz
w. www.figureandground.co.nz

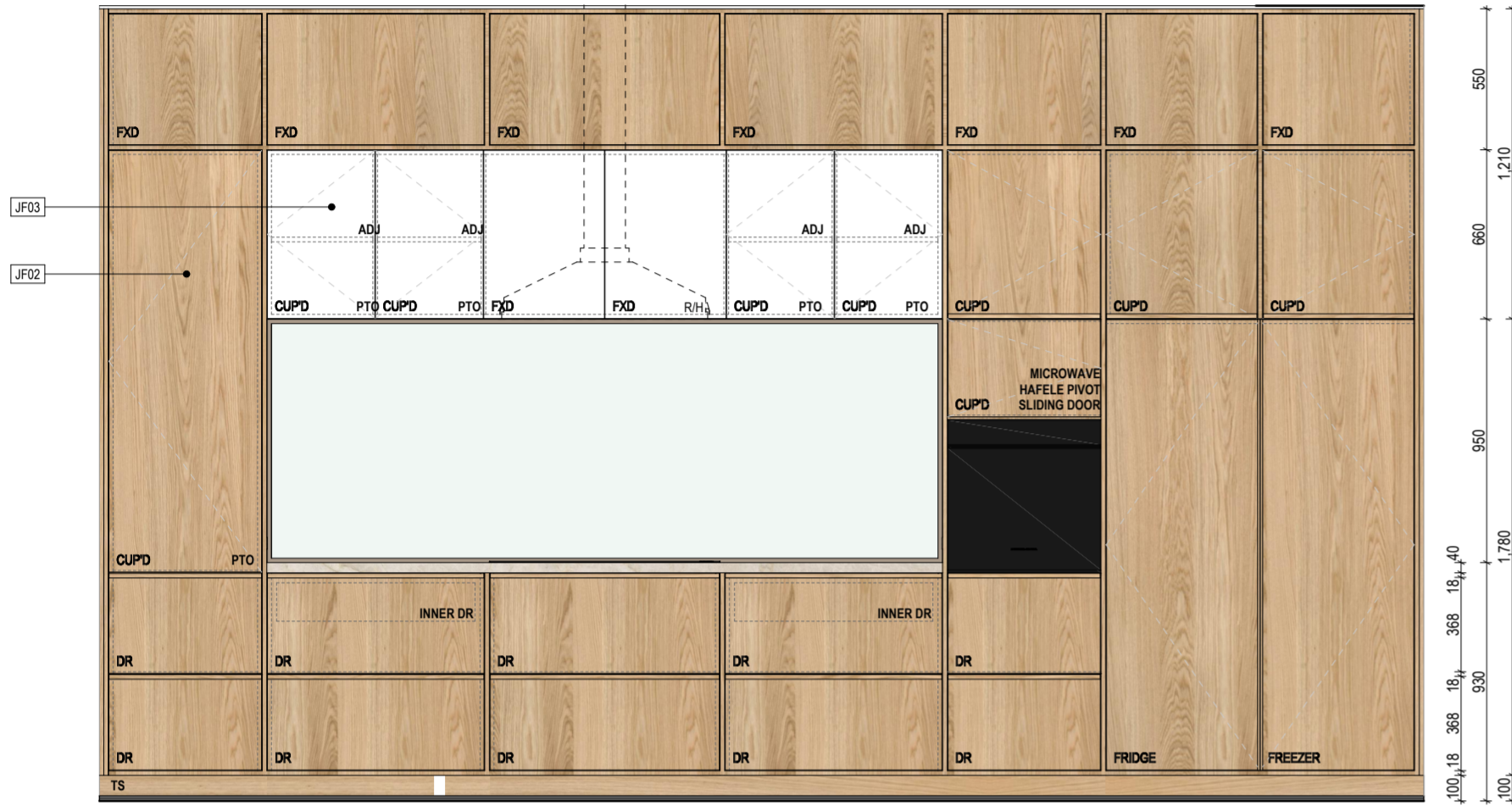

01 Back Wall Elevation

SCALE: 1:25

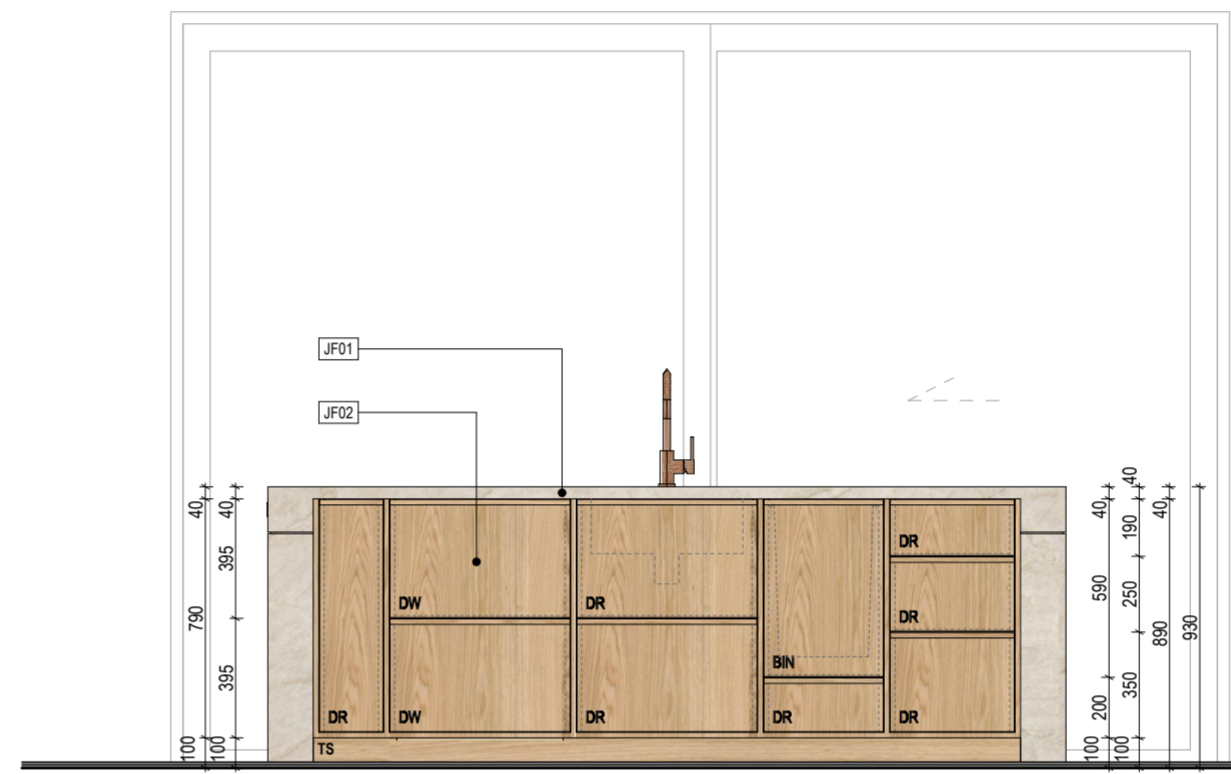

02 Island Back Elevation

SCALE: 1:25

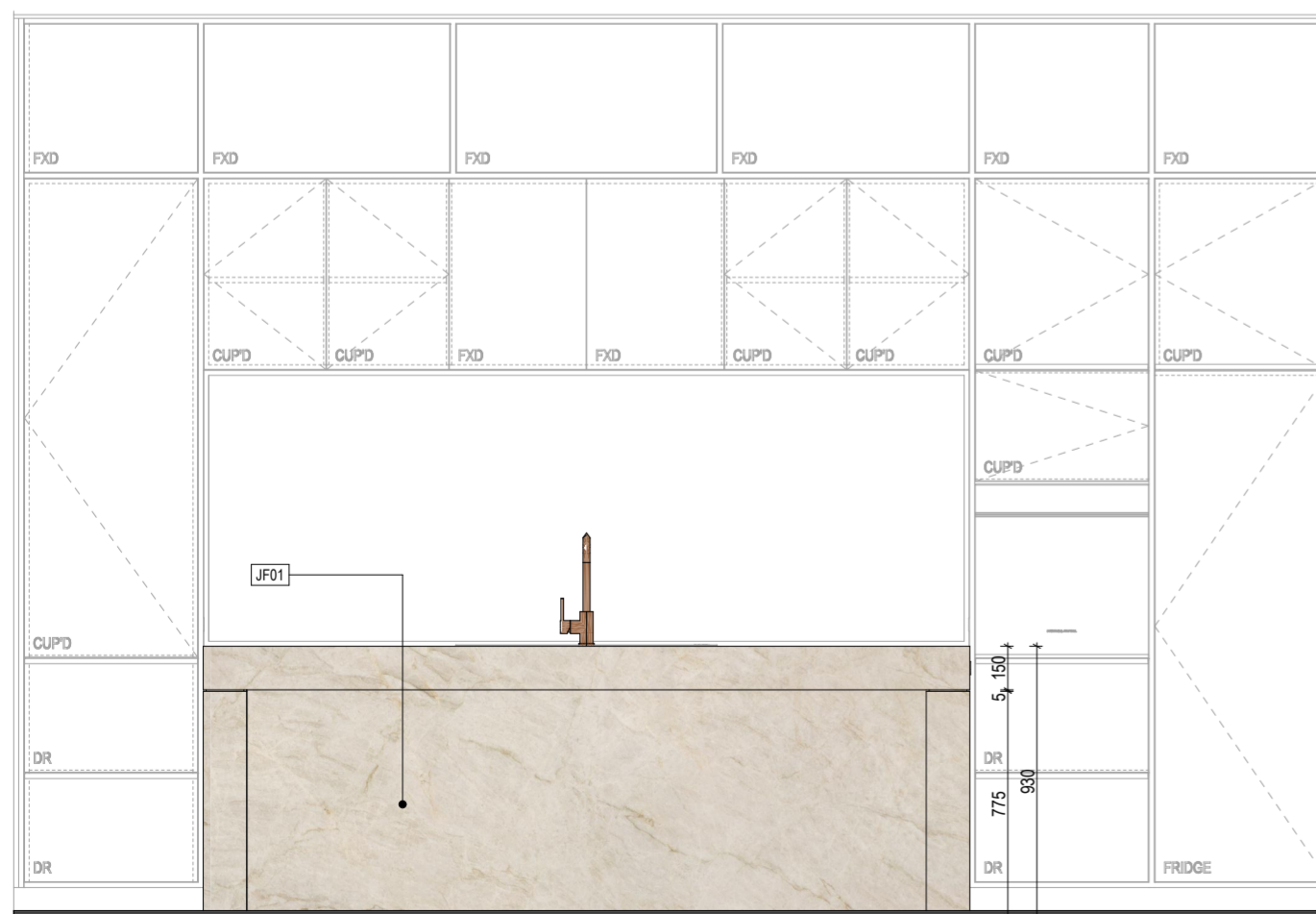

03 Island Front Elevation

SCALE: 1:25



04 Island End Elevation

SCALE: 1:25

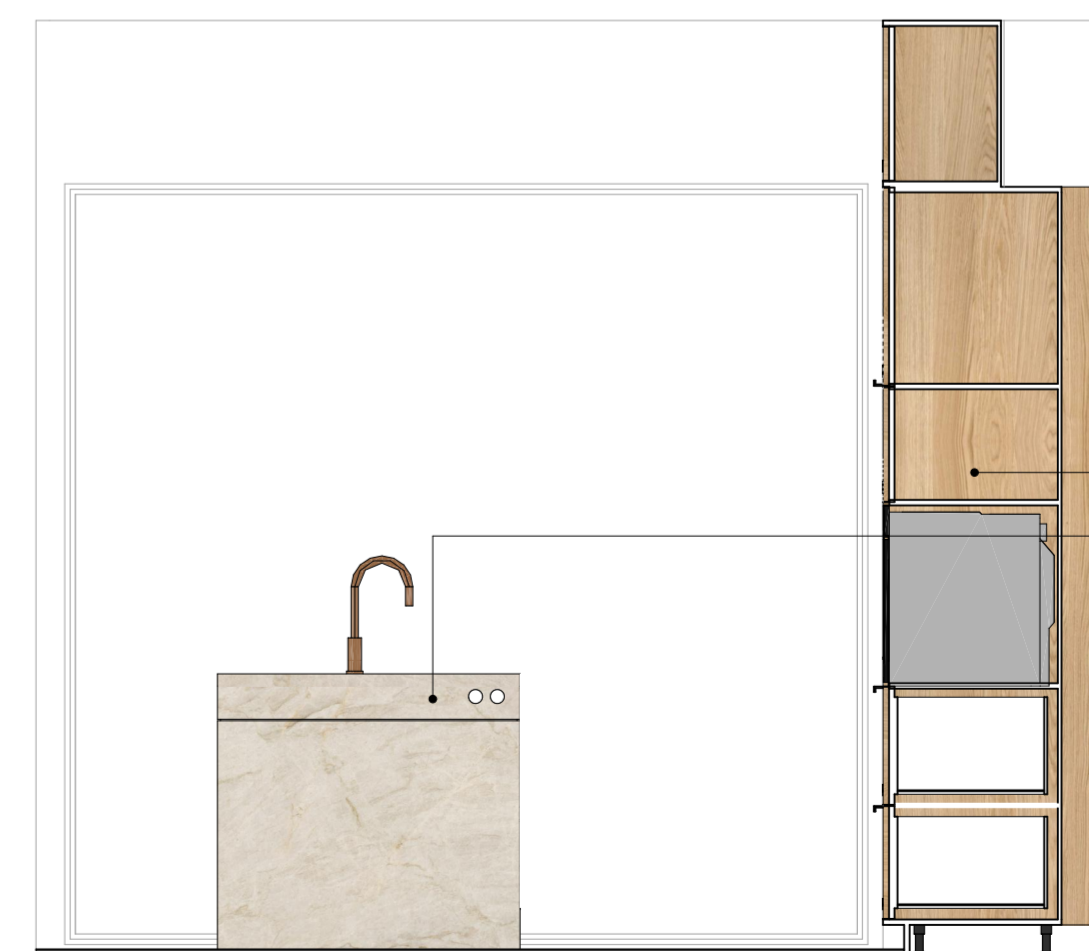

05 Island End Elevation

SCALE: 1:25

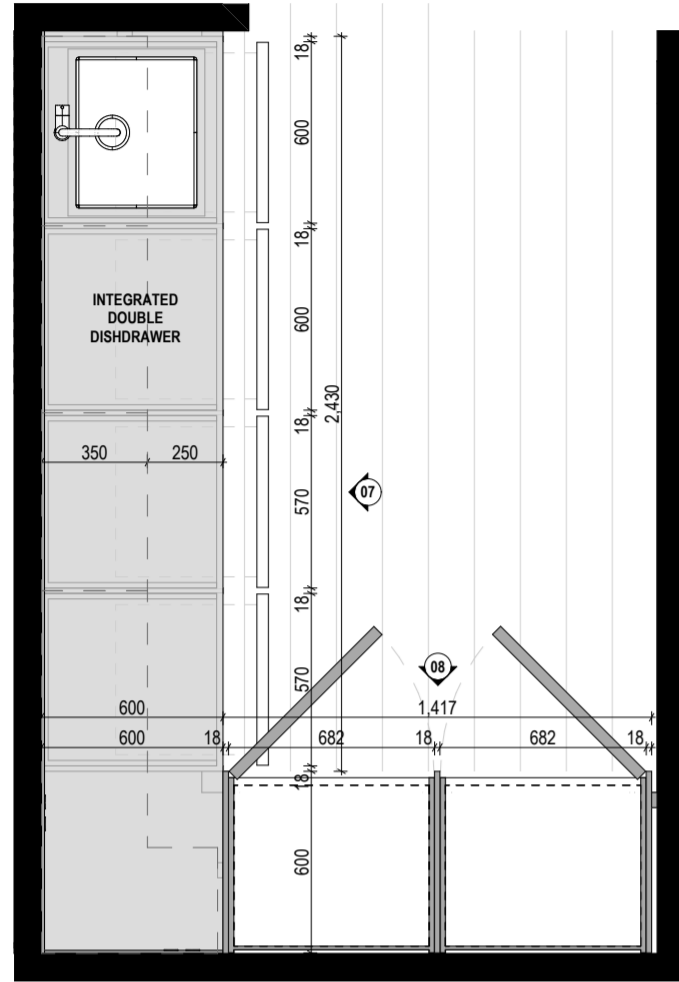

Kitchen Plan
SCALE: 1:25

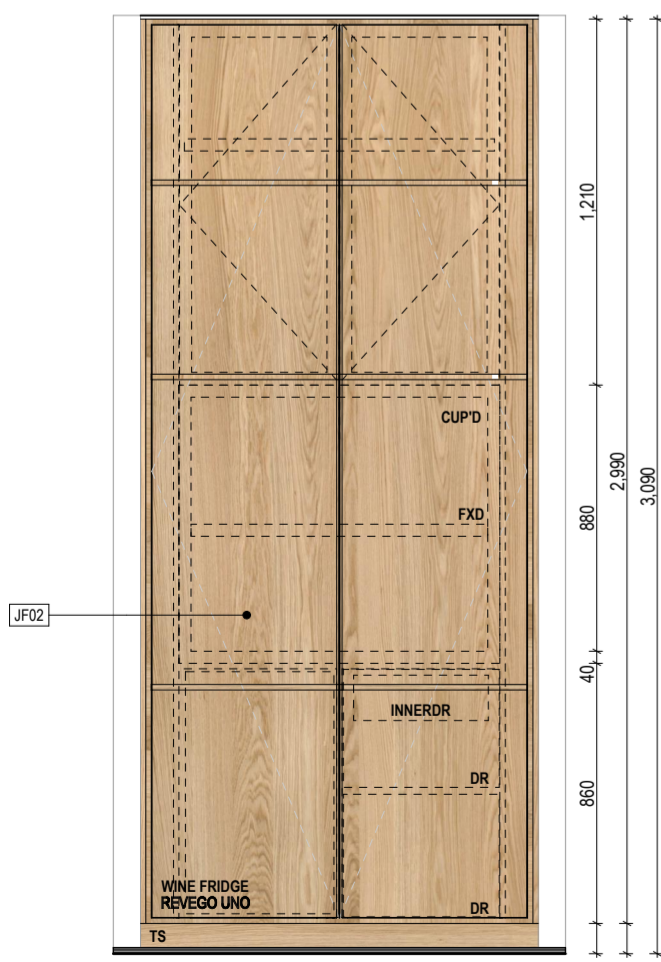

06 Breakfast Bar Elevation
SCALE: 1:25

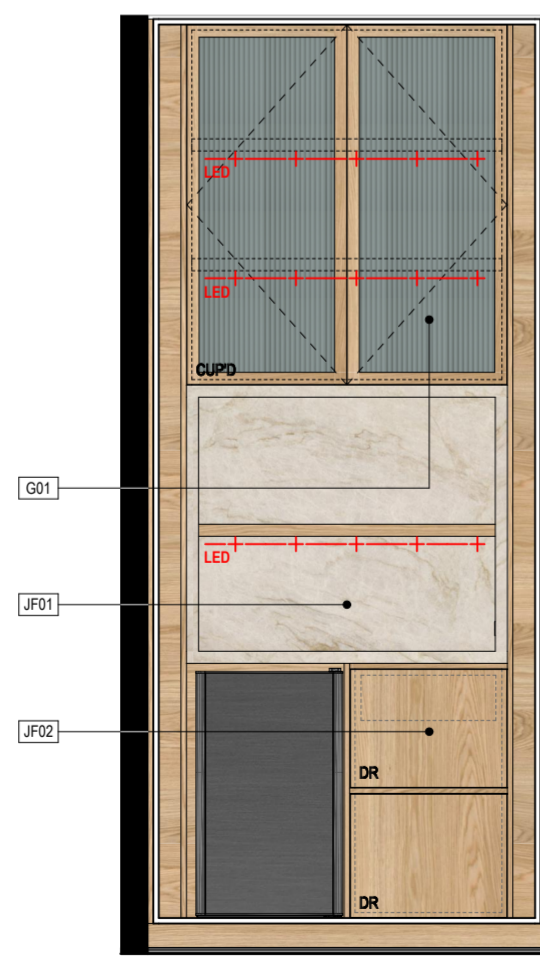

07 Breakfast Bar Internal
SCALE: 1:25



08 Scullery Elevation

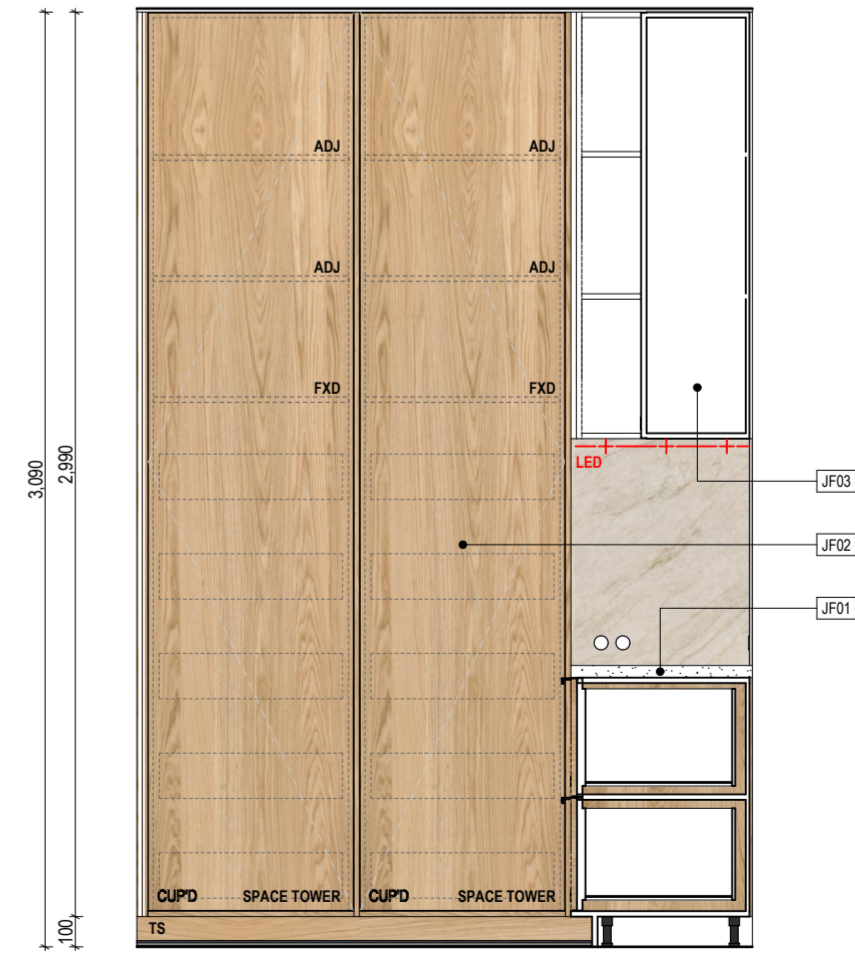

09 Scullery Elevation

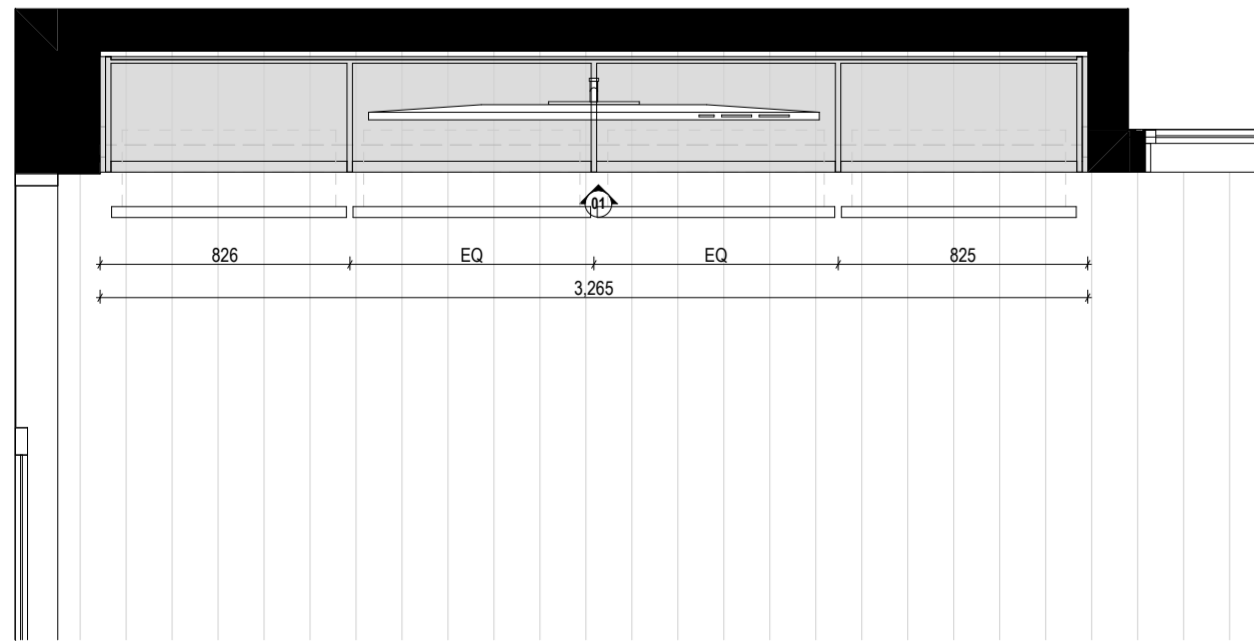

Living Plan

SCALE: 1:25

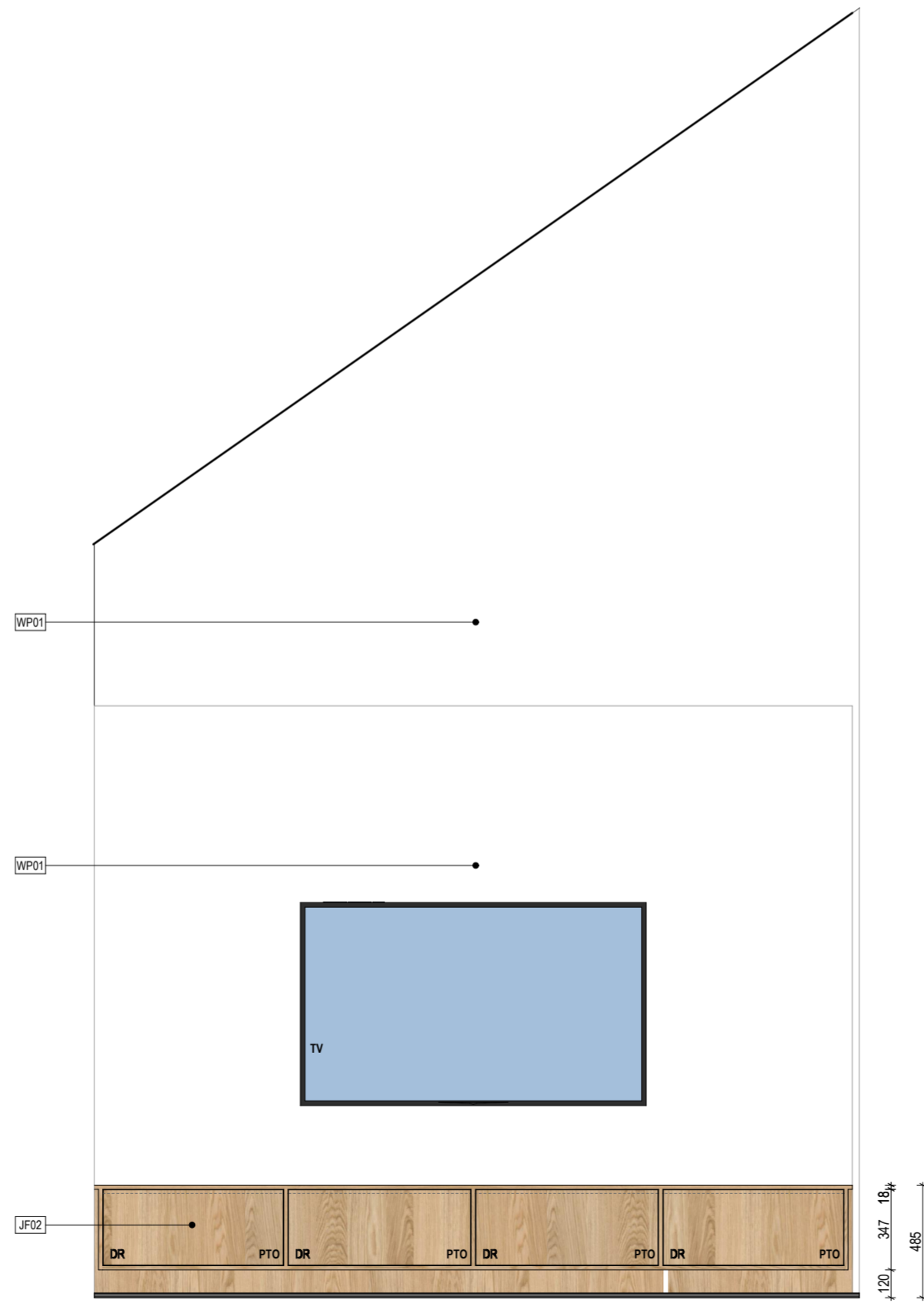

01 Living Elevation

SCALE: 1:25



Living Perspective



FIGURE & GROUND

292 Kennedys Bush Road
Kennedys Bush
Christchurch

Living.

Drawing Sheet **A6.10**

File 25.1029
Date 11/12/2025
Drawn BM
Revision **D**

Figure & Ground
Level 1, 4 Walker Street
Christchurch Central 8011

p. 03 352 4333
e. studio@figureandground.co.nz
w. www.figureandground.co.nz

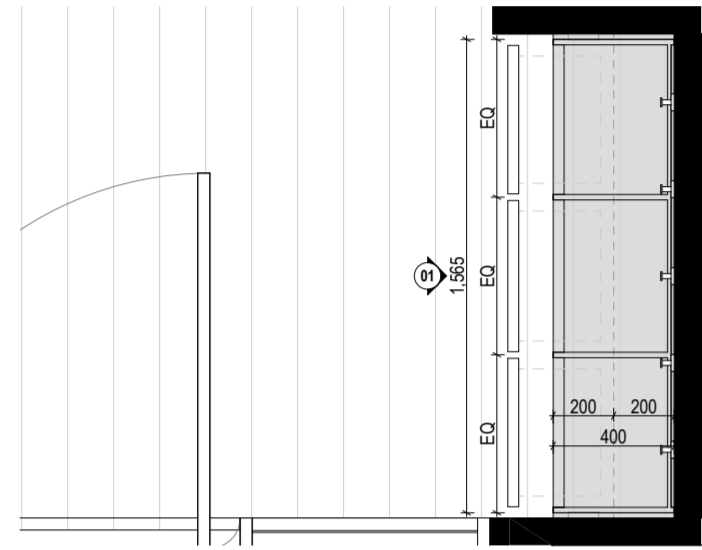

Entry Plan
SCALE: 1:25

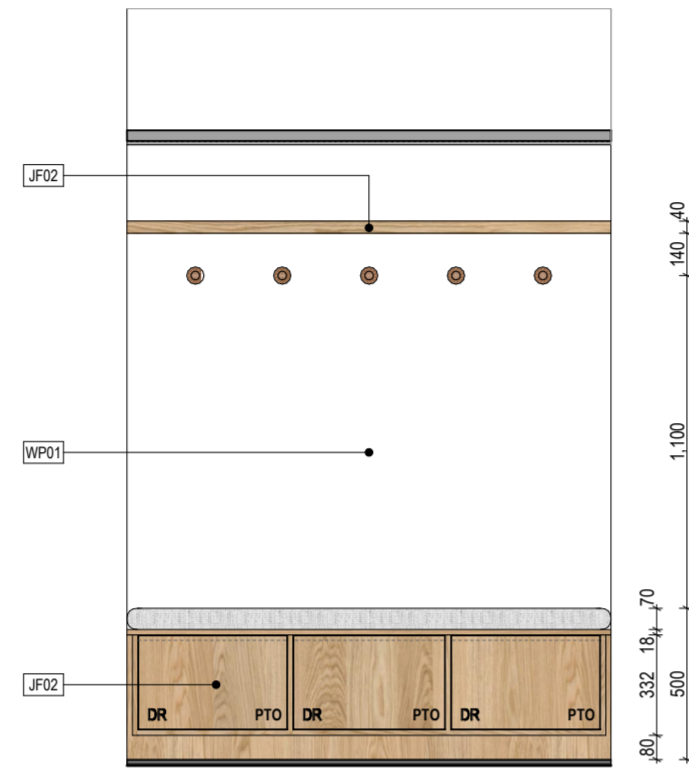

01 Entry Elevation
SCALE: 1:25

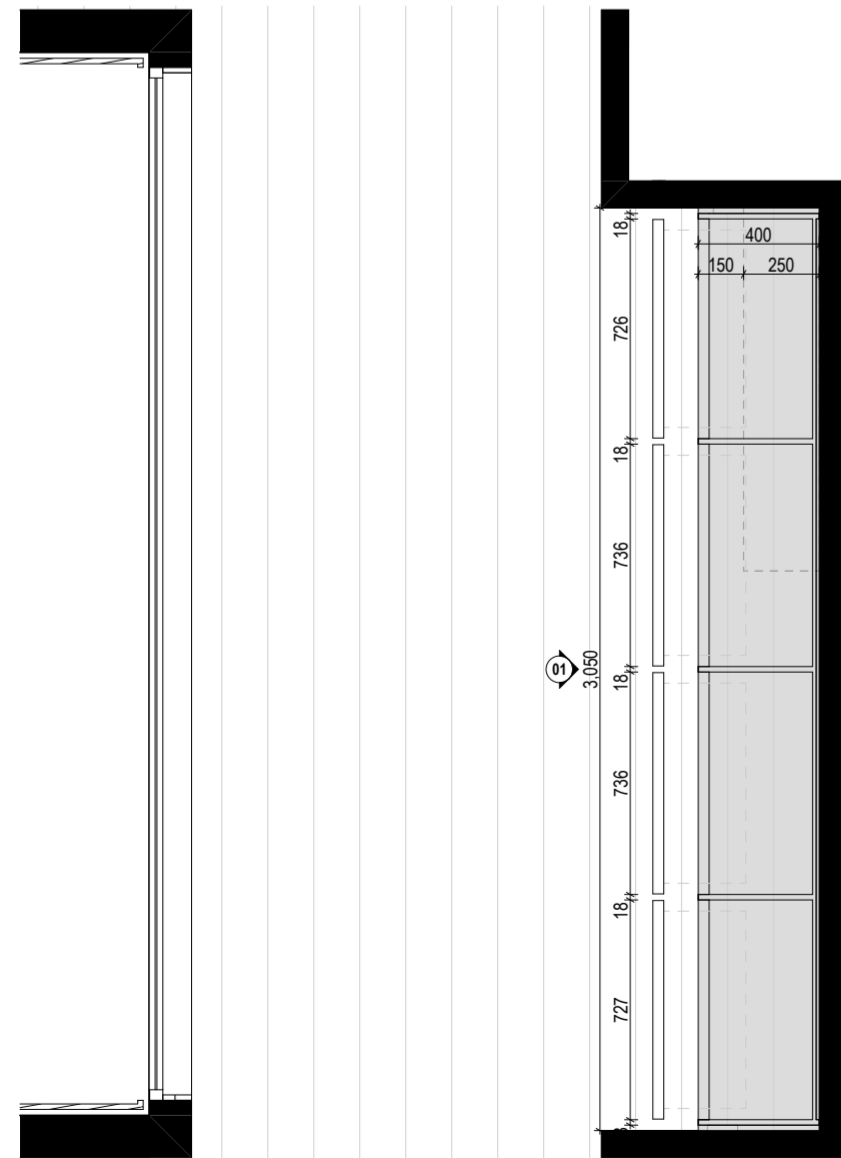

Hallway Plan
SCALE: 1:25

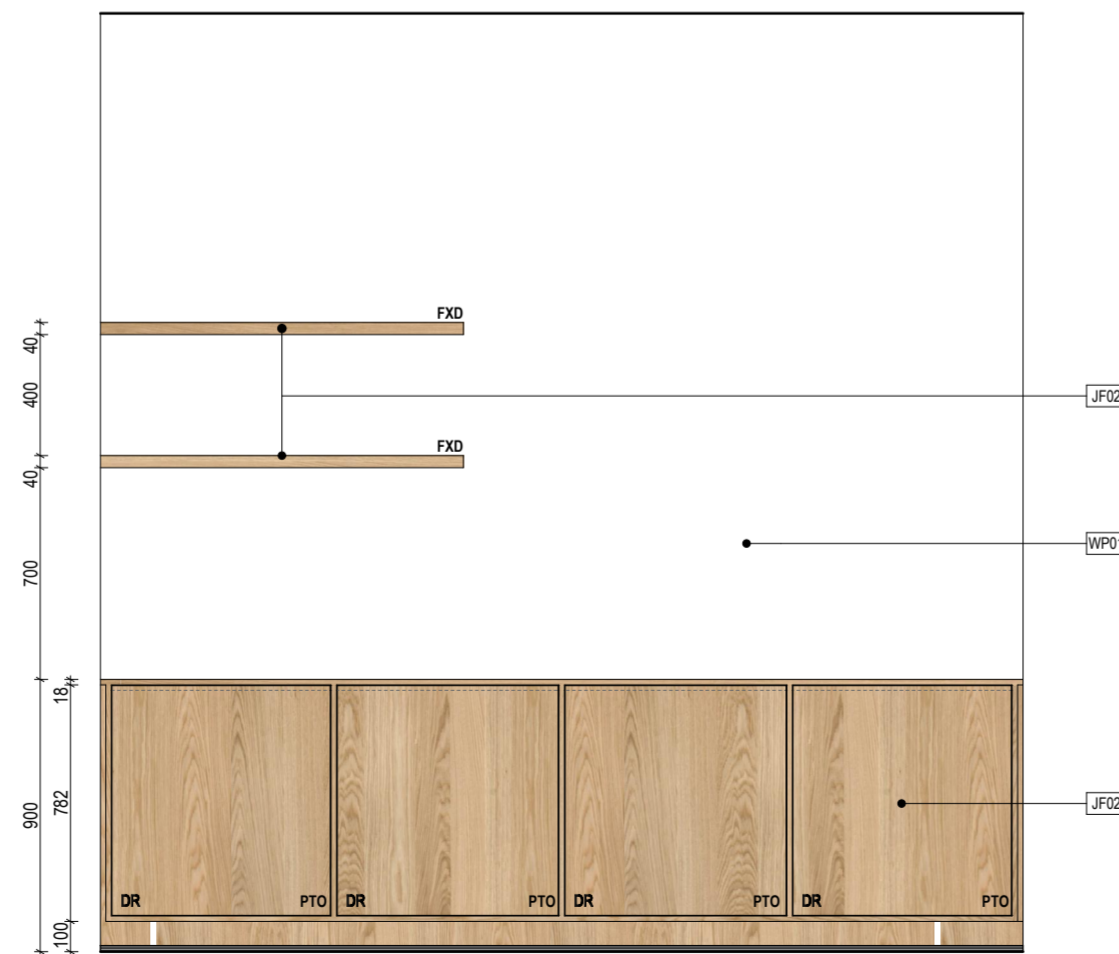

01 Hallway Elevation
SCALE: 1:25

D	Interior Concept	11/12/2025
---	------------------	------------

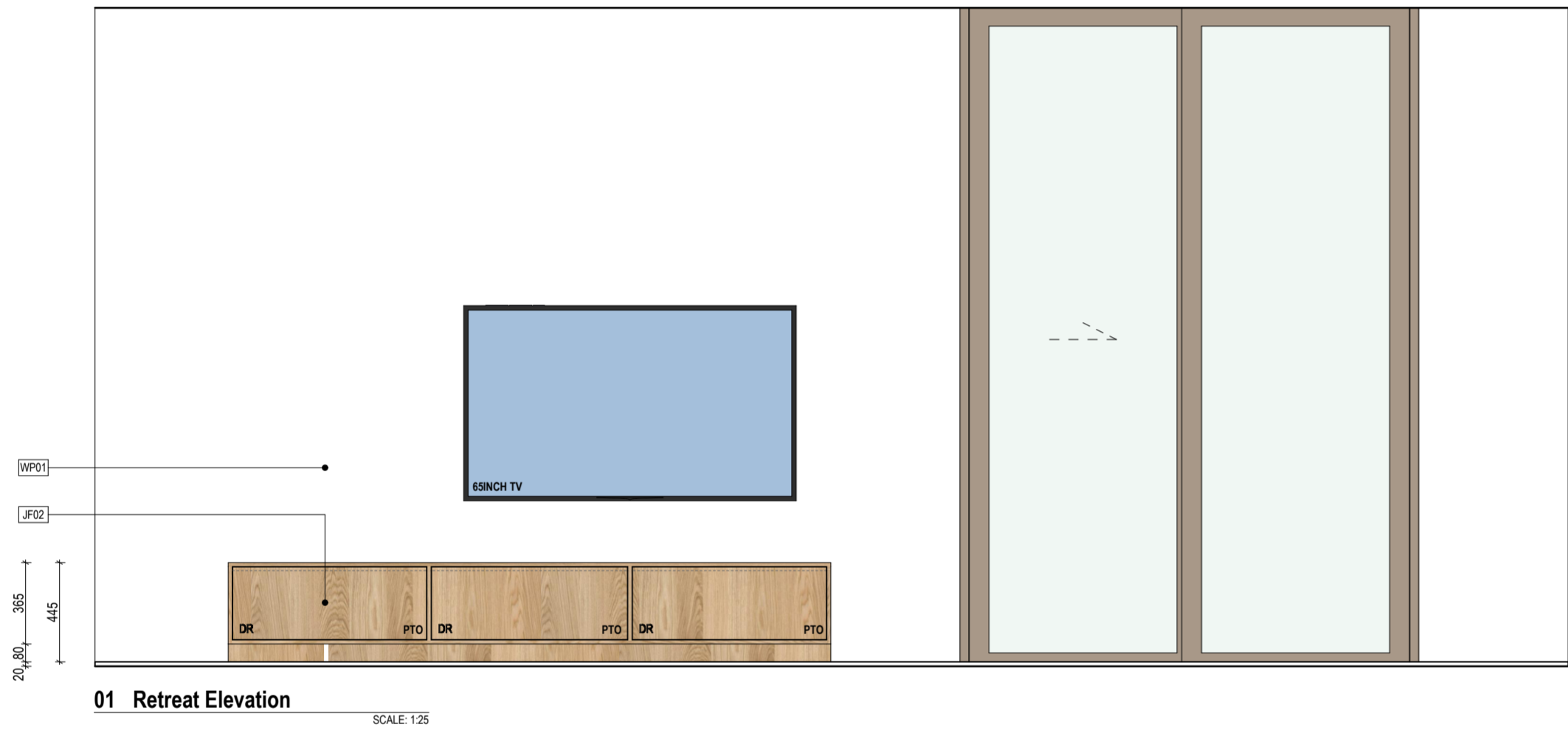

FIGURE & GROUND

292 Kennedys Bush Road
Kennedys Bush
Christchurch

Retreat.

Drawing Sheet	A6.12
File	25.1029
Date	11/12/2025
Drawn	BM
Revision	D

Figure & Ground
Level 1, 4 Walker Street
Christchurch Central 8011

p. 03 352 4333
e. studio@figureandground.co.nz
w. www.figureandground.co.nz

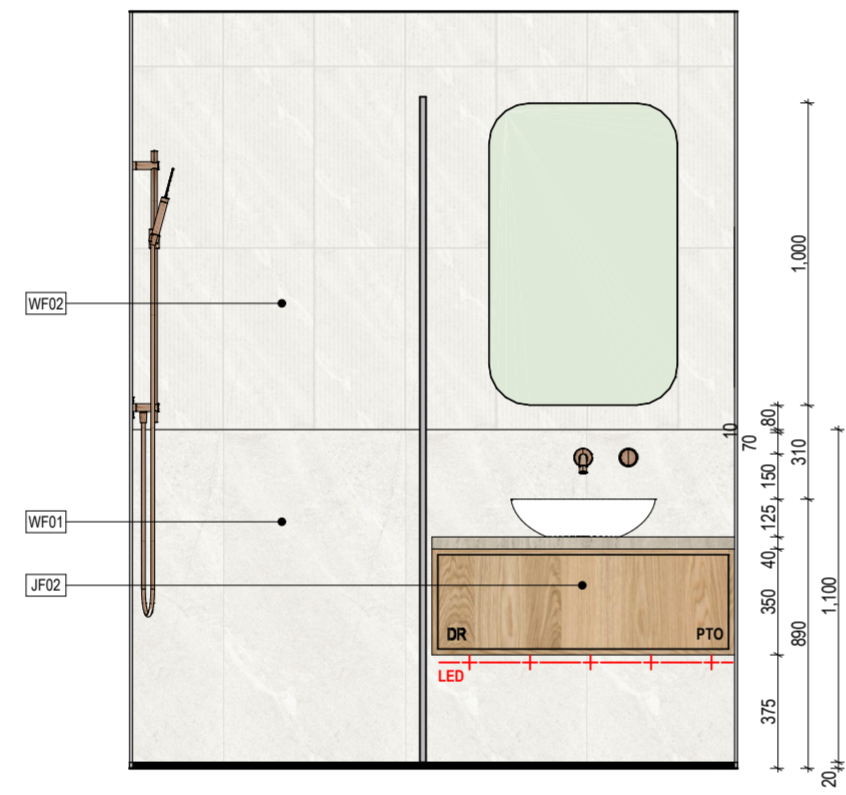

01 Bathroom Elevation
SCALE: 1:25



01 Bathroom Perspective



02 Bathroom Perspective

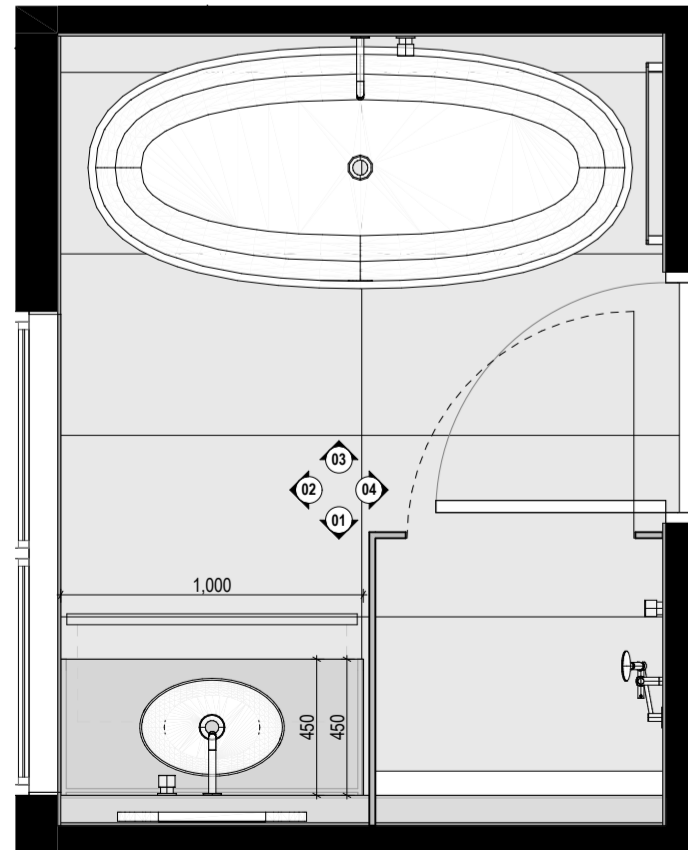

Bathroom Plan
SCALE: 1:25

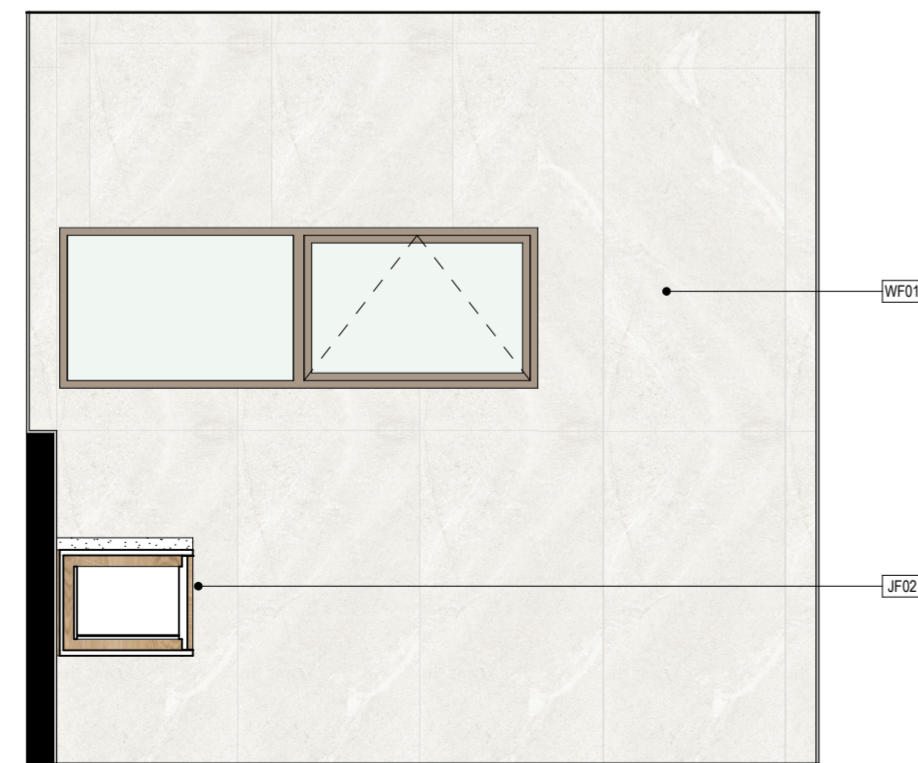

02 Bathroom Elevation
SCALE: 1:25



03 Bathroom Elevation
SCALE: 1:25

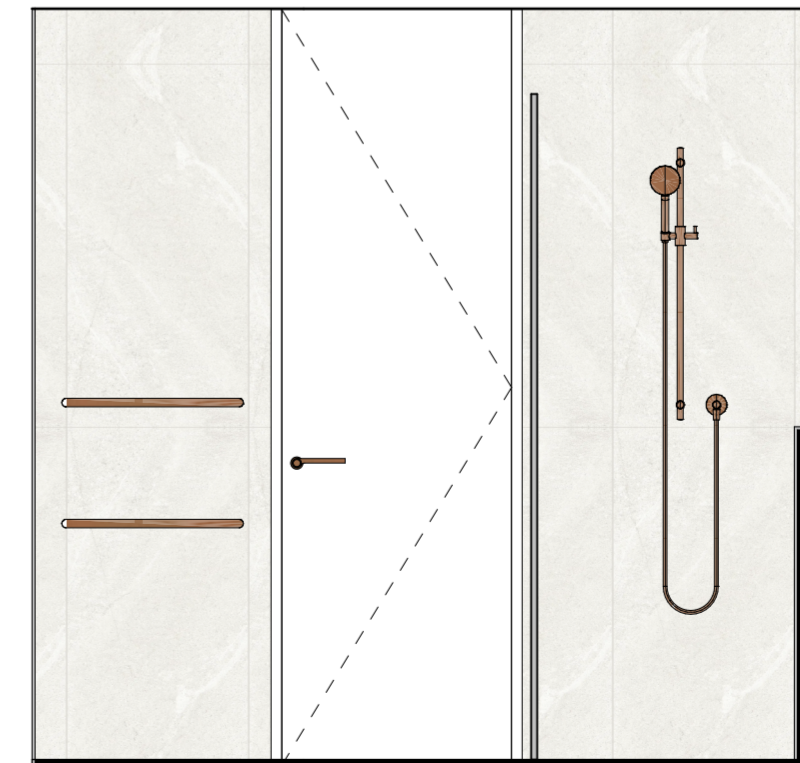

04 Bathroom Elevation
SCALE: 1:25

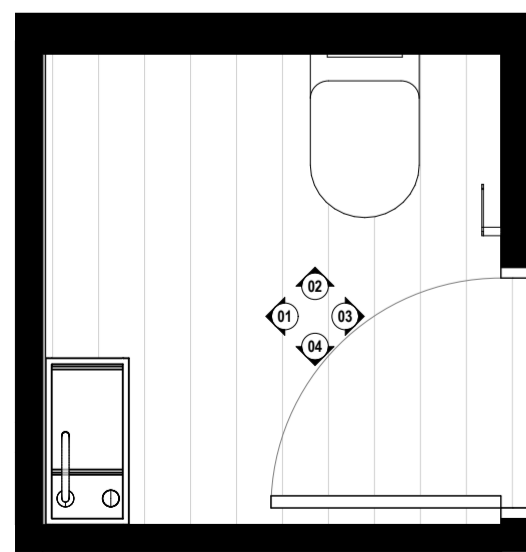

Powder Room Plan
SCALE: 1:25



Powder Room Perspective

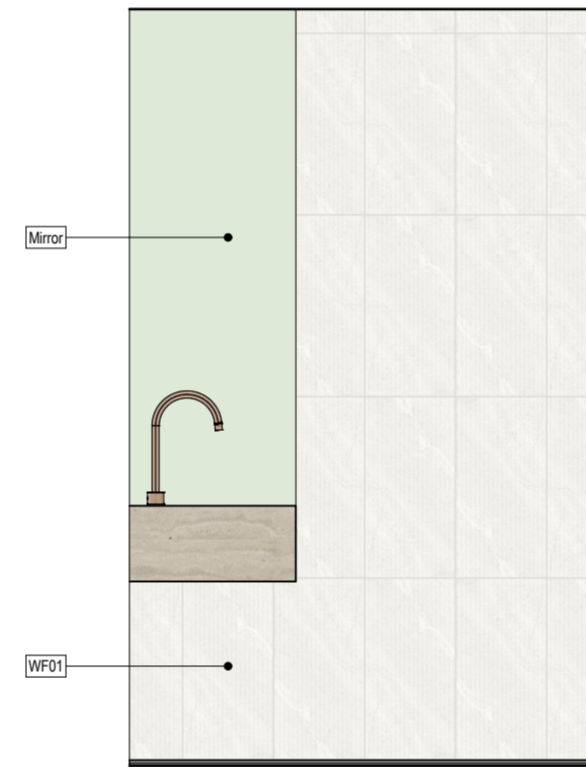

01 Powder Room Elevation
SCALE: 1:25

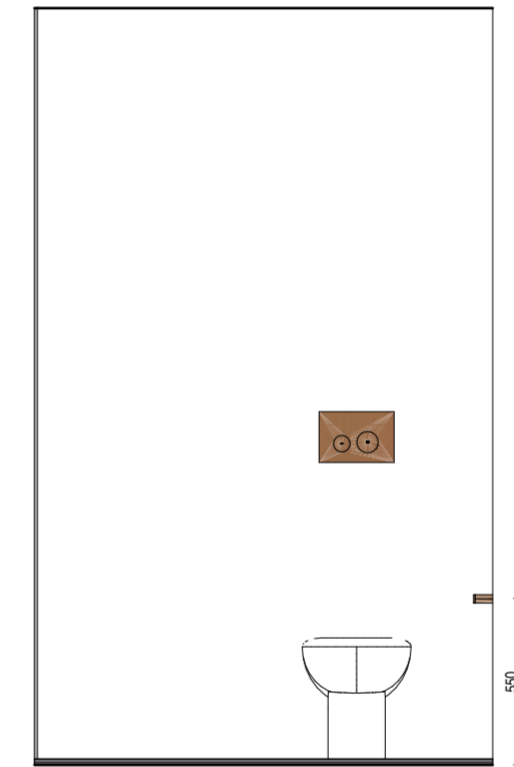

02 Powder Room Elevation
SCALE: 1:25

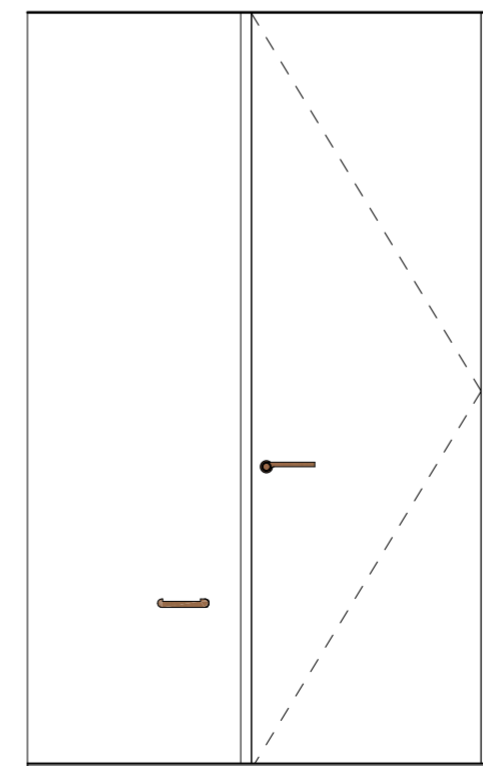

03 Powder Room Elevation
SCALE: 1:25

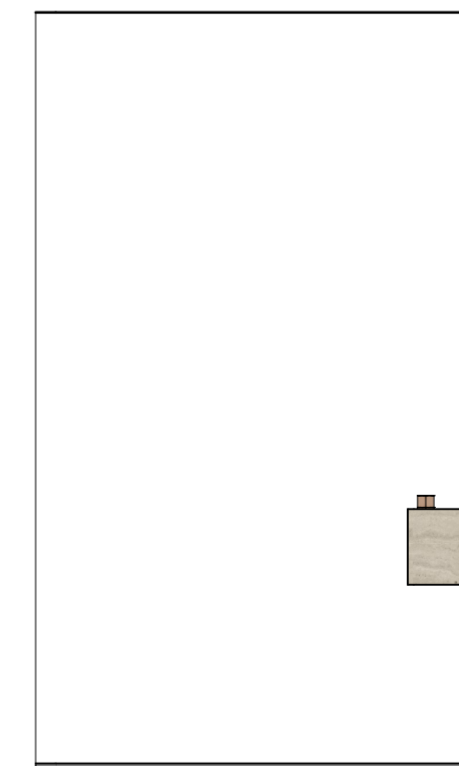

04 Powder Room Elevation
SCALE: 1:25

D	Interior Concept	11/12/2025
---	------------------	------------

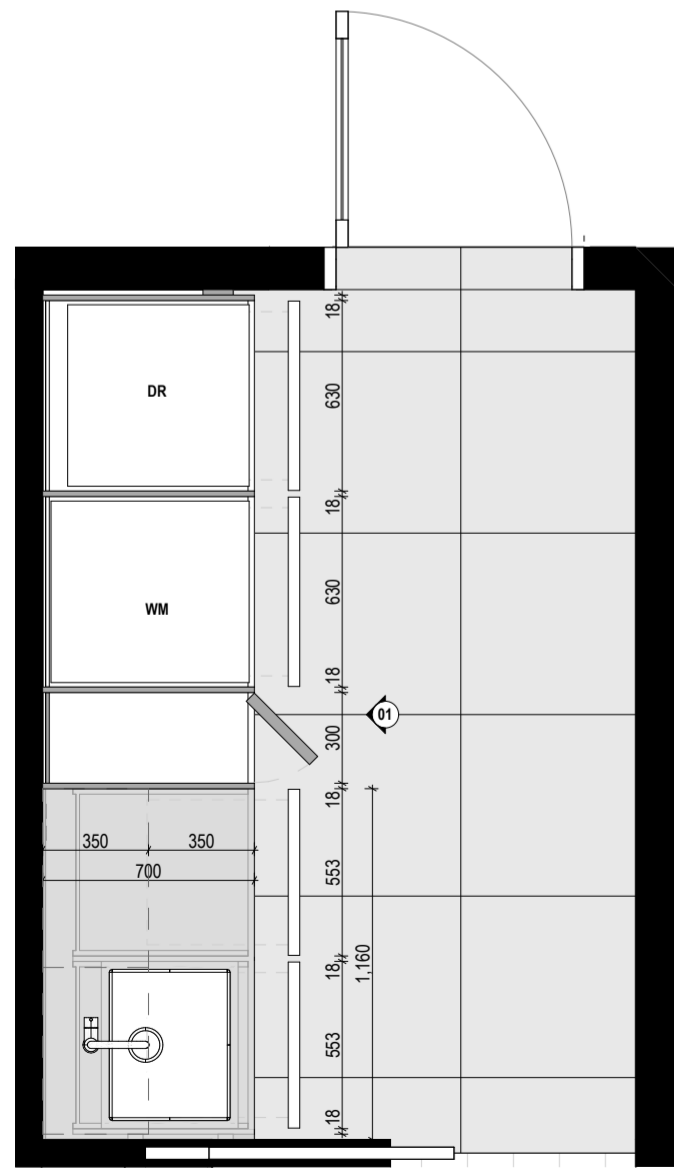

Laundry Plan
SCALE: 1:25

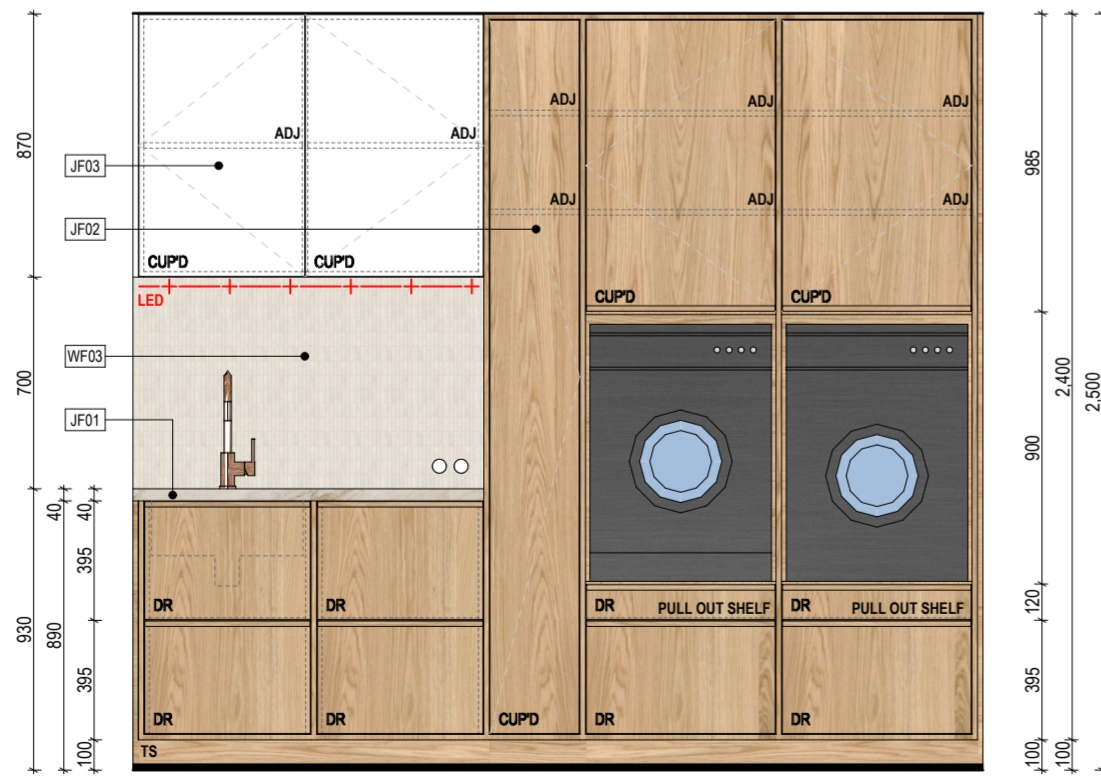

01 Laundry Elevation
SCALE: 1:25



Laundry Perspective



FIGURE & GROUND

292 Kennedys Bush Road
Kennedys Bush
Christchurch

Laundry.

Drawing Sheet **A6.15**

File 25.1029
Date 11/12/2025
Drawn BM
Revision **D**

Figure & Ground
Level 1, 4 Walker Street
Christchurch Central 8011

p. 03 352 4333
e. studio@figureandground.co.nz
w. www.figureandground.co.nz

D	Interior Concept	11/12/2025

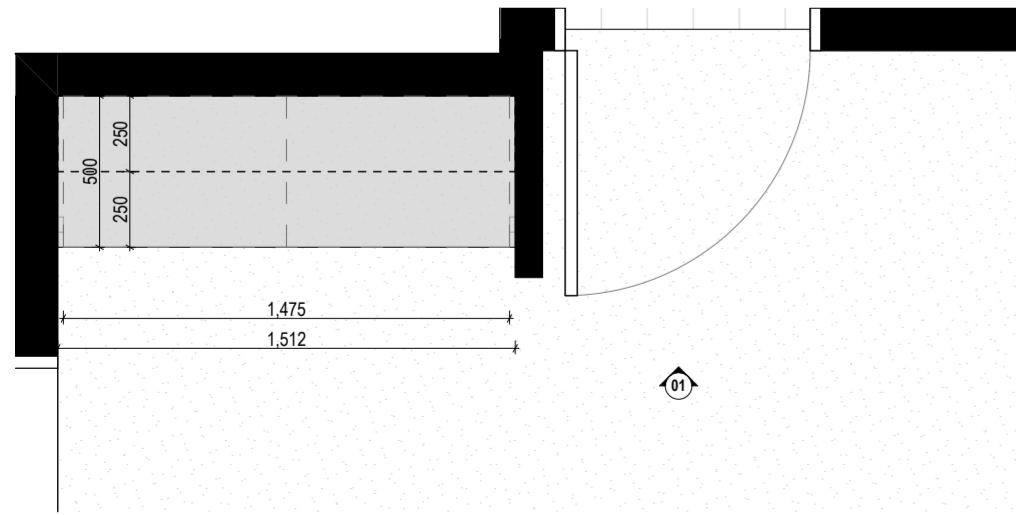

Bedroom 01 Plan
SCALE: 1:25

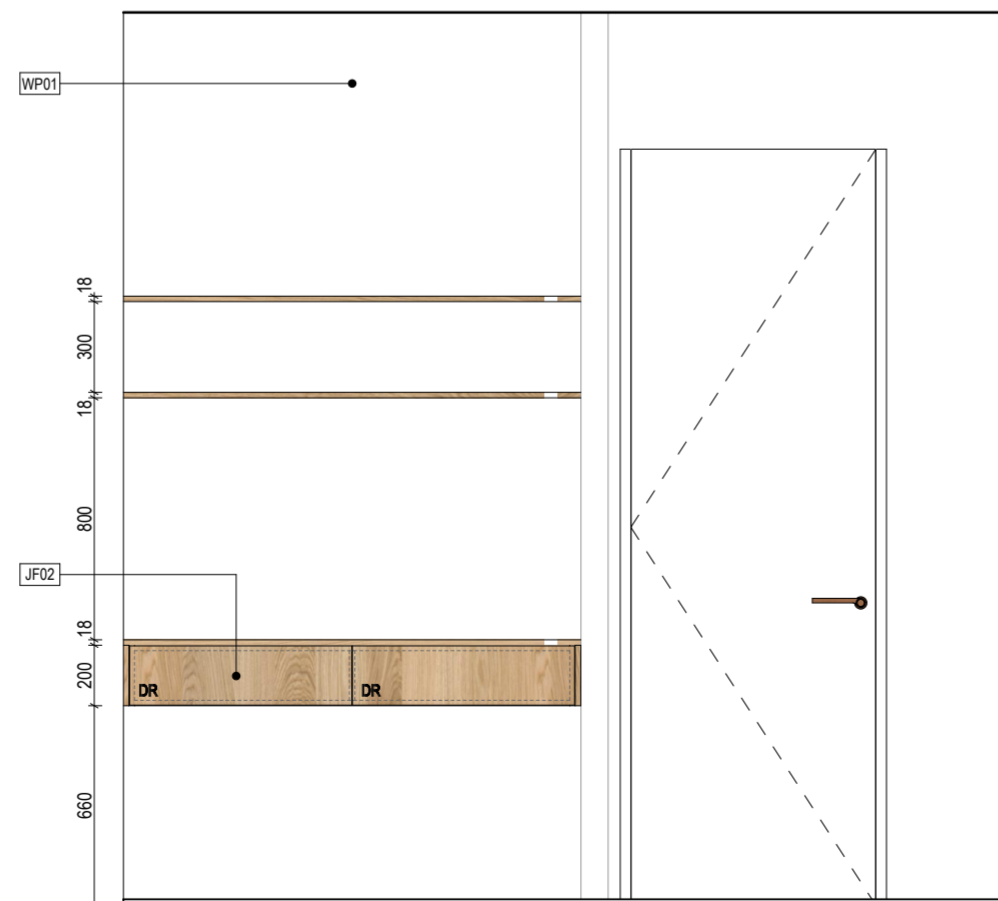

01 Bedroom 01 Elevation
SCALE: 1:25



FIGURE & GROUND

292 Kennedys Bush Road
Kennedys Bush
Christchurch

Bedroom 01.

Drawing Sheet	A6.16
File	25.1029
Date	11/12/2025
Drawn	BM
Revision	D

Figure & Ground
Level 1, 4 Walker Street
Christchurch Central 8011

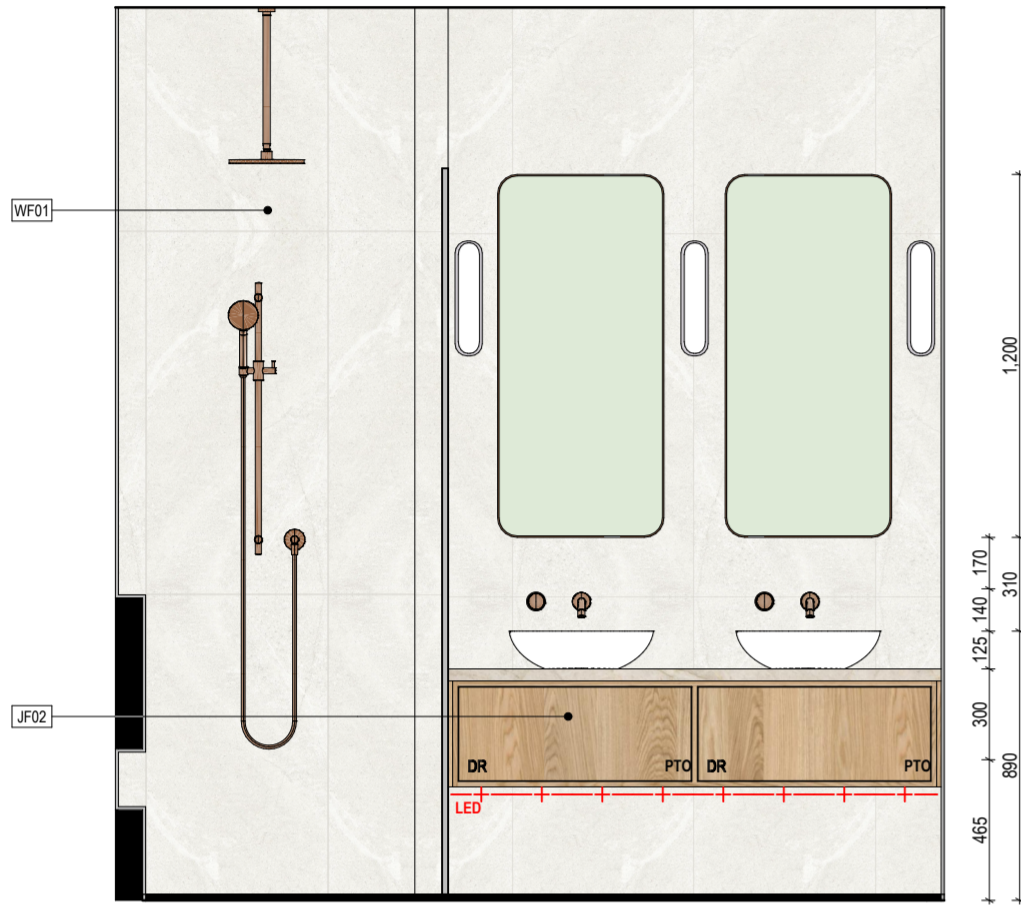

01 Ensuite Elevation
SCALE: 1:25



02 Ensuite Elevation
SCALE: 1:25



03B Ensuite Elevation
SCALE: 1:25



03A Ensuite Elevation
SCALE: 1:25

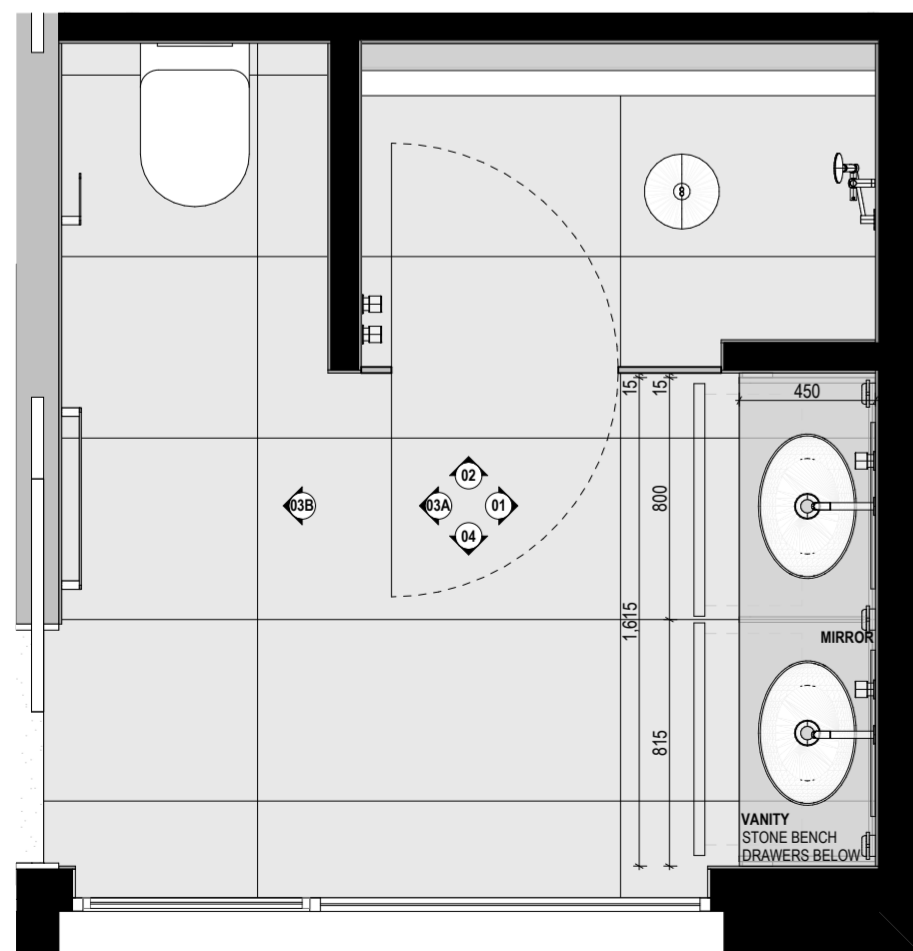

Ensuite Plan
SCALE: 1:25



04 Ensuite Elevation
SCALE: 1:25



01 Ensuite Perspective

D	Interior Concept	11/12/2025
---	------------------	------------

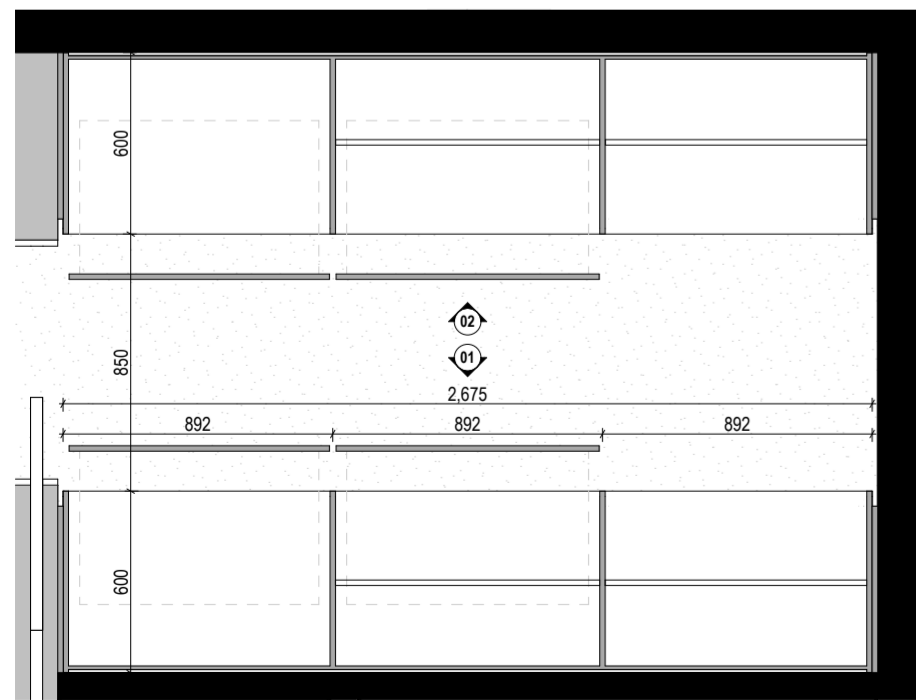

Walk In Robe Plan
SCALE: 1:25



01 WIR Elevation
SCALE: 1:25



02 WIR Elevation
SCALE: 1:25



FIGURE & GROUND

292 Kennedys Bush Road
Kennedys Bush
Christchurch

Walk In Robe.

Drawing Sheet **A6.18**

File 25.1029
Date 11/12/2025
Drawn BM
Revision **D**

Figure & Ground
Level 1, 4 Walker Street
Christchurch Central 8011

p. 03 352 4333
e. studio@figureandground.co.nz
w. www.figureandground.co.nz



01 Ensuite 02 Perspective



02 Ensuite 02 Perspective

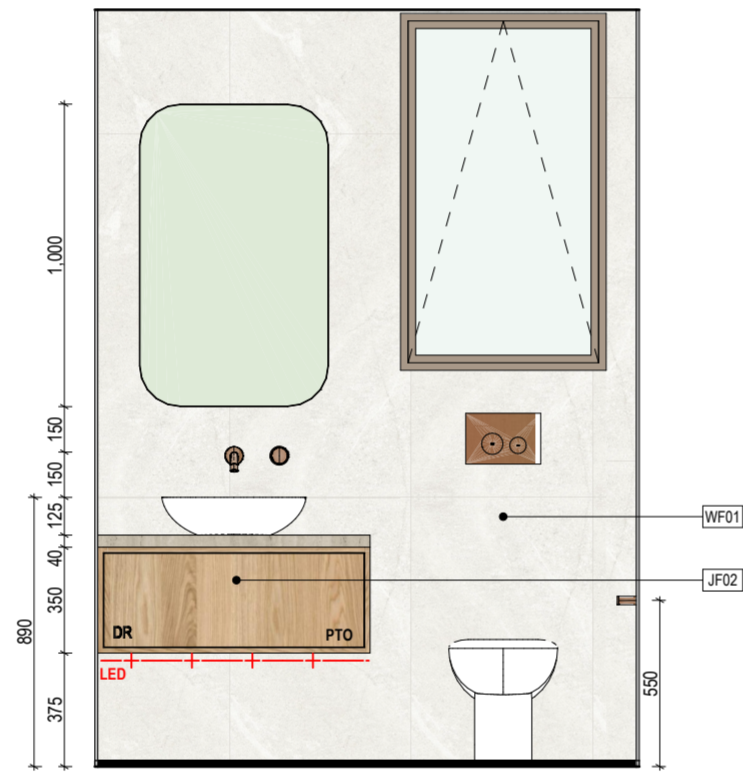

01 Ensuite 2 Elevation

SCALE: 1:25

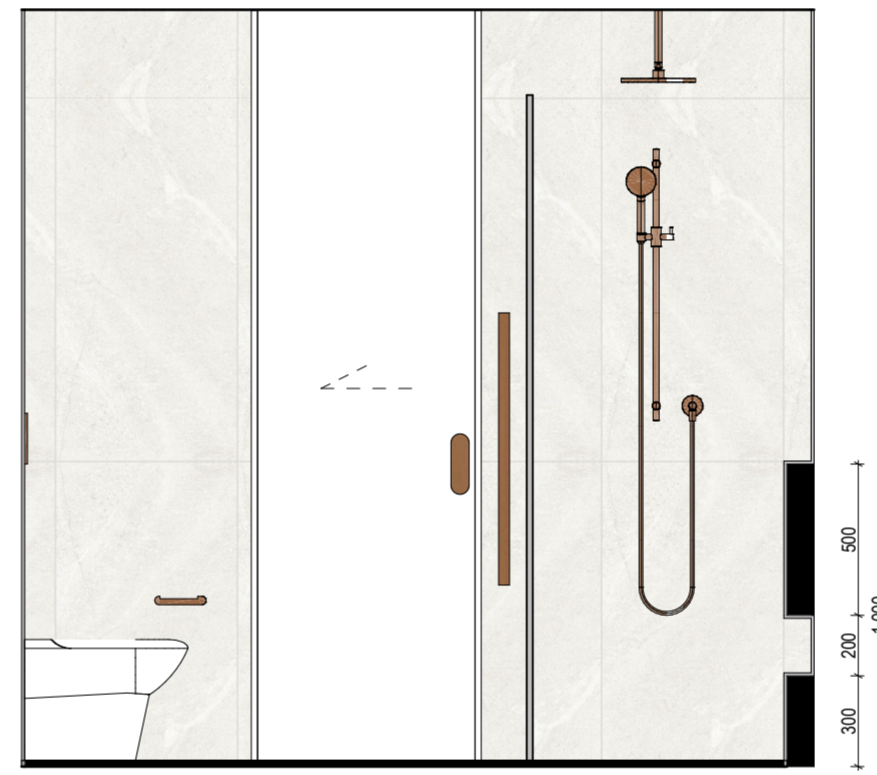

02 Ensuite 2 Elevation

SCALE: 1:25

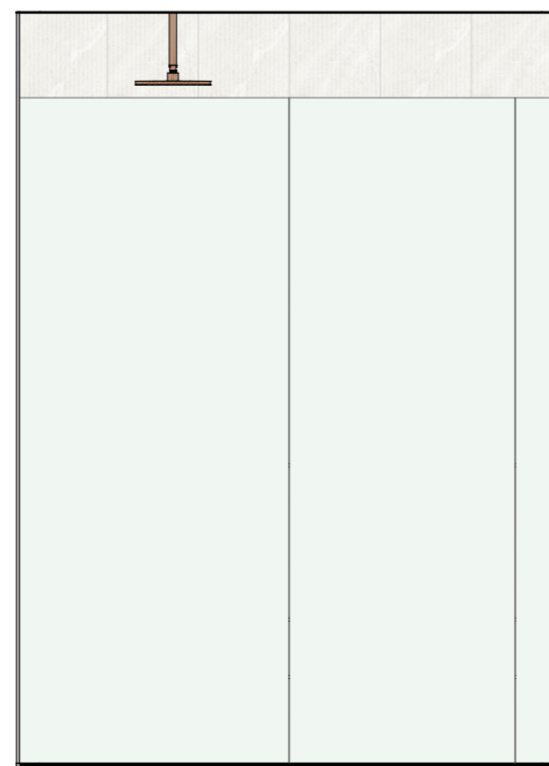

03A Ensuite 2 Elevation

SCALE: 1:25

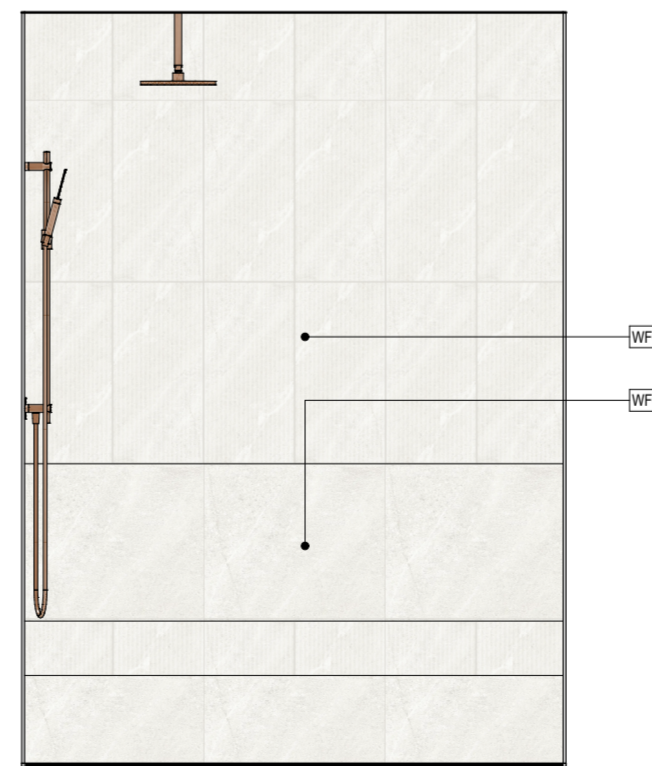

03B Ensuite 2 Elevation

SCALE: 1:25



04 Ensuite 2 Elevation

SCALE: 1:25

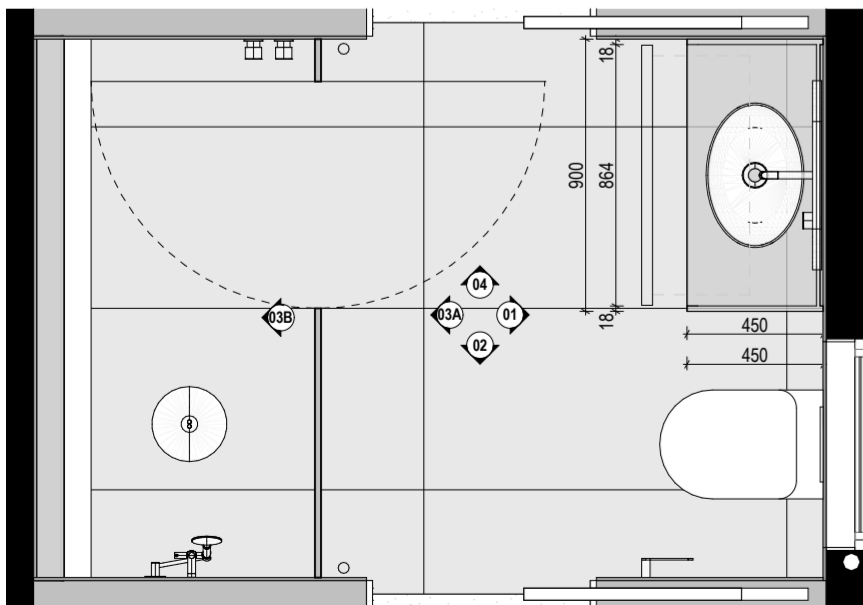

Ensuite 02 Plan

SCALE: 1:25

